

**Crashworthiness Evaluation
Side Impact Crash Test
Protocol (Version III)**

September 2004

**INSURANCE INSTITUTE
FOR HIGHWAY SAFETY**

1005 NORTH GLEBE ROAD ARLINGTON, VA 22201

PHONE 703/247-1500 FAX 703/247-1678

<http://www.highwaysafety.org>

Insurance Institute for Highway Safety Side Impact Crash Test Protocol (Version III)

Document Revision History

Version III of the Insurance Institute for Highway Safety *Side Impact Crash Test Protocol* differs from Version II in the following ways:

The moving deformable barrier (MDB) vertical center of gravity has been updated to reflect official measurements taken at an inertial measurement facility; and

Roll, pitch, and yaw moments of inertia have also been added to the MDB specifications.

Version II of the protocol differs from Version I in the following ways:

In addition to postcrash photographs of the vehicle taken with the struck-side doors on, photos are also taken with the door skins removed, then again with the doors removed;

Additional structural measures are recorded on the struck and non-struck-side B-pillar interior. In addition the postcrash coordinate system is now reestablished using reference points that are recorded precrash; and

Pubic force load measurement is eliminated.

Test Conditions

Impact Configuration

Side impact crash tests consist of a stationary test vehicle struck on the driver's side by a crash cart fitted with an Insurance Institute for Highway Safety (IIHS) deformable barrier element (version 4). The 1,500 kg moving deformable barrier (MDB) has an impact velocity of 50 km/h (31.1 mi/h) and strikes the vehicle on the driver's side at a 90° angle. The longitudinal impact point of the barrier on the side of the test vehicle is dependent on the vehicle's wheelbase. The impact reference distance (IRD) is defined as the distance rearward from the test vehicle's front axle to the closest edge of the deformable barrier when it first contacts the vehicle (Figure 1). Evaluation testing of the impact configuration has been previously reported (Dakin et al., 2003).

IRD calculation:

If wheelbase < 250 cm, then IRD = 61 cm

If 250 cm ≤ wheelbase ≤ 290 cm, then IRD = (wheelbase ÷ 2) – 64 cm

If wheelbase > 290 cm, then IRD = 81 cm

The MDB is accelerated by the propulsion system until it reaches the test speed (50 km/h) and then is released from the propulsion system 25 cm before the point of impact with the test vehicle. The MDB braking system, which applies the test cart's service brakes on all four wheels, is activated 1.0 seconds after it is released from the propulsion system. The brakes on the test vehicle are not activated during the crash test.

Figure 1
Moving Deformable Barrier Alignment with Test Vehicle

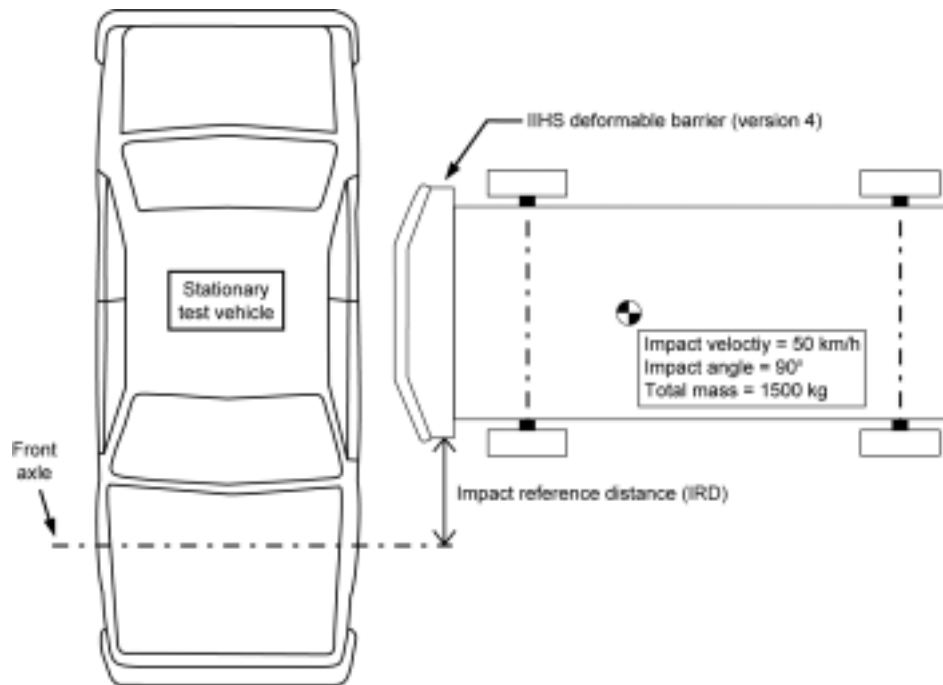

IIHS MDB Properties

The MDB consists of an IIHS deformable aluminum barrier (version 4) and the cart to which it is attached. The crash cart is similar to the one used in Federal Motor Vehicle Safety Standard (FMVSS) 214 side impact testing but has several modifications (Figure 2). The wheels on the cart are aligned with the longitudinal axis of the cart (0 degrees) to allow for perpendicular impact. The front aluminum mounting plate has been raised 100 mm higher off the ground and has been extended 200 mm taller than a standard FMVSS 214 cart to accommodate the IIHS deformable barrier element (making the mounting plate's top surface 300 mm higher from the ground than the FMVSS 214 barrier). Steel plates are added as necessary to increase the mass of the cart. The MDB test weight is $1,500 \pm 5$ kg with the deformable element, test instrumentation, camera, and camera mount. The MDB center of gravity in the fully equipped test condition is 990 ± 25 mm rearward of the front axle, 0 ± 25 mm from the lateral centerline, and 566 ± 25 mm from the ground. The MDB roll (I_x), pitch (I_y), and yaw (I_z) moments of inertia are $542 \text{ kg}\cdot\text{m}^2$, $2,471 \text{ kg}\cdot\text{m}^2$, and $2,757 \text{ kg}\cdot\text{m}^2$, respectively.

The deformable element is 1,676 mm wide, has a height of 759 mm, and a ground clearance of 379 mm when mounted on the test cart (Figure 3). Detailed information on the IIHS barrier development and evaluation testing has been documented previously (Arbelaez et al., 2002).

Figure 2
IIHS Test Cart with Deformable Barrier Element Attached

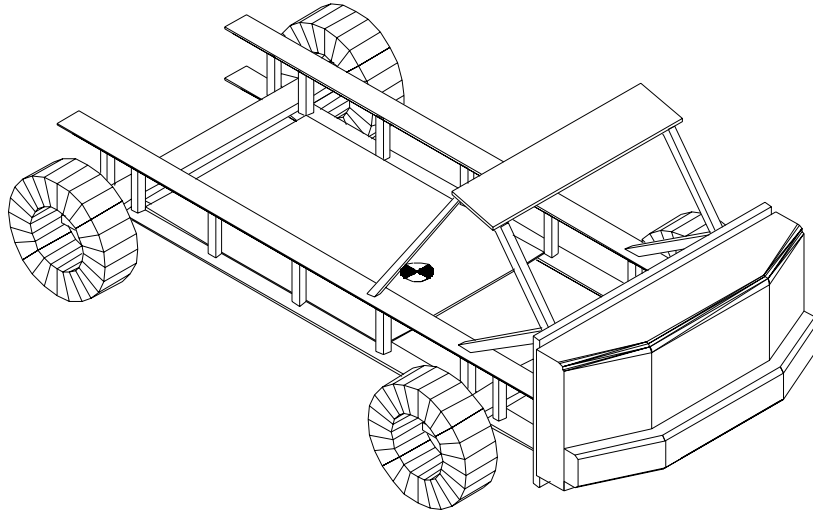
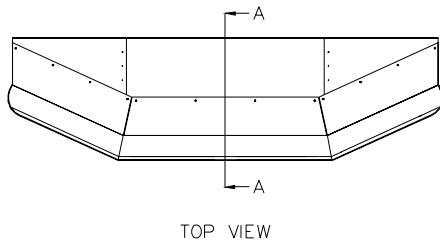
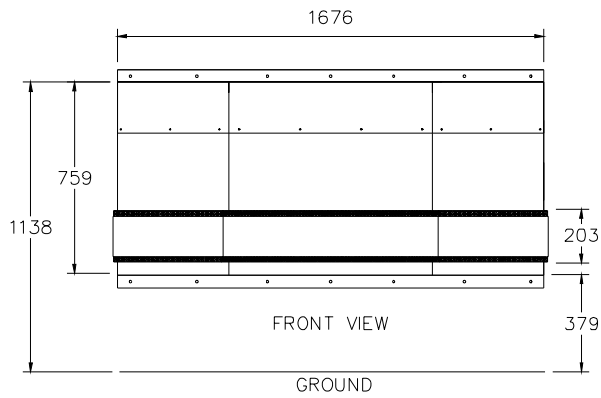
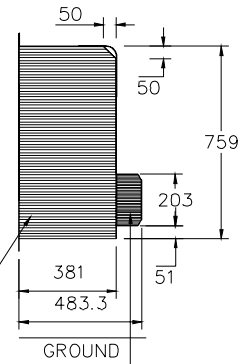

Figure 3
IIHS Deformable Barrier Element (Version 4)
(all measurements in millimeters)



SECTION A-A



Aluminum Honeycomb Bumper,
 1690 kpa ± 103 kpa crush strength

Aluminum Honeycomb Block,
 310 kpa ± 17 kpa crush strength

Test Vehicle Preparation

Test Vehicle Selection and Acquisition

Each vehicle is inspected upon arrival at the research center. Vehicles are examined to verify that they are in satisfactory operating condition and to note defects such as prior collision damage, missing parts, maladjustments, or fluid leaks. If directly relevant to testing, such deficiencies are corrected or a replacement vehicle is procured.

Many of the vehicles evaluated in the side impact test program have been used in the IIHS low-speed crash test program. Such vehicles have been subjected to an impact on the front and/or rear of the vehicle at 5 mi/h (8 km/h) (IIHS, 2002a). Any structural damage pertinent to side impact protection is repaired or replaced before the side impact crash test. Cosmetic damage is repaired at IIHS's discretion. Parts are replaced or repaired as appropriate based on the judgment of professional insurance appraisers.

Fluids

The gasoline is removed from the fuel tank and fuel lines and replaced with Stoddard solvent to full capacity within 48 hours of the test. The fuel pump is run for a short period to ensure the Stoddard solvent has filled the fuel lines. The air conditioning system's refrigerant is recovered by methods that comply with applicable environmental regulations.

Test Vehicle Instrumentation

An aluminum instrumentation rack, which supports the test equipment, is bolted to the floor in the cargo area of the test vehicle. The carpeting in this area is removed to allow access to the floor. The spare tire, accessory jack, tool compartments, and 3rd row seats may be removed, if necessary. A 12-volt battery and monitoring system is installed on the instrumentation rack. This system supplies electrical power for the time-zero indicator lights and the two Denton Intelligent Dummy Data Acquisition Systems (IDDAS). A two-conductor cable connects this battery to the vehicle's battery terminals. The system weighs 32 kg.

Two instrumentation/camera mount platforms are installed on the nonstruck side of the vehicle at locations adjacent to the front and rear passenger window sills. Two data acquisition units, one for each of the SID-II dummies, are secured to these platforms. Three onboard high-speed cameras (500 frames per second) also are mounted on the platforms to observe dummy kinematics throughout the crash.

A plastic block containing an array of high-intensity light-emitting diodes (LED) is attached to the roof of the vehicle with sheet metal screws. Additional LEDs are placed inside the vehicle in view of the onboard high-speed cameras. A pressure-sensitive tape switch is applied to the driver's side of the vehicle such that it makes first contact with the barrier during the crash. Pressure applied to this tape completes an electrical circuit that signals the start of the crash (time-zero) for the data acquisition systems and illuminates all the LEDs.

If floor mats are standard or offered as an option through the manufacturer or dealership, they are installed in the driver footwell and left rear passenger floorpan.

The location of the vehicle's precrash center of gravity is marked with a photographic target applied to the appropriate top surface of the vehicle (Figure 4).

The interior rearview mirror, front passenger head restraint, and passenger side windows are removed to prevent possible obstruction of camera views during the test.

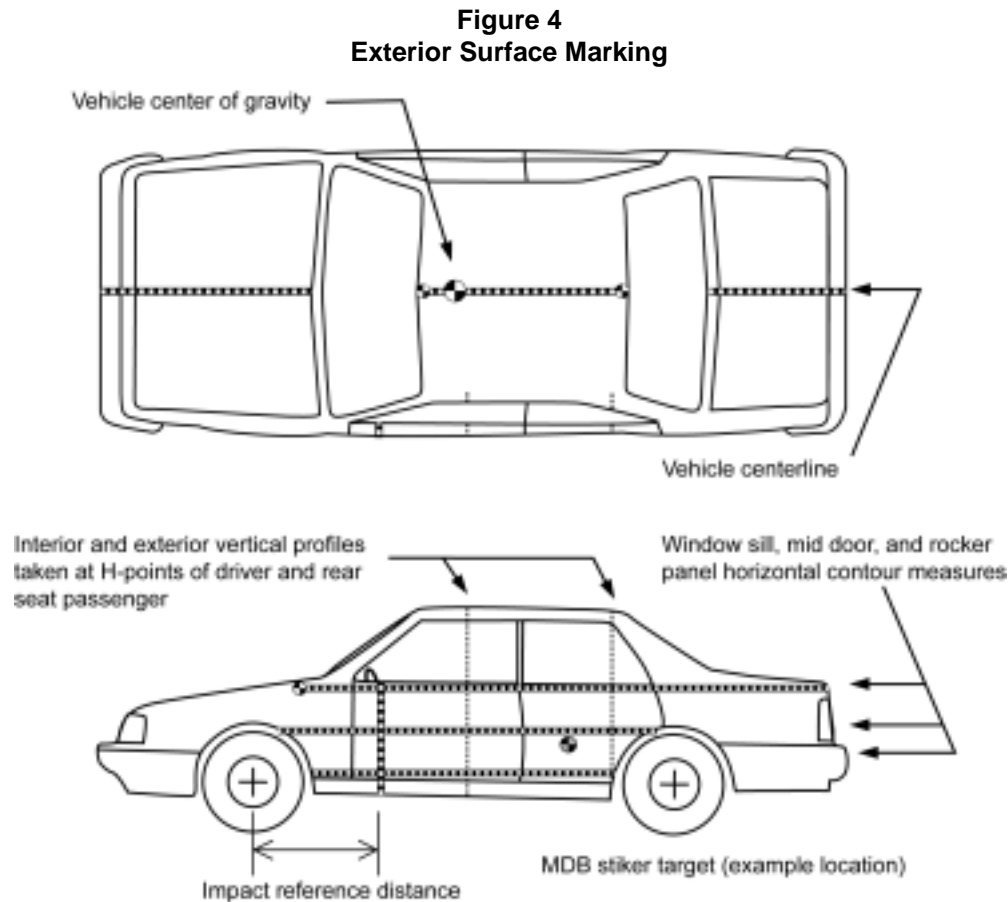

Attachment of Antiroll Device to Vehicles with High Centers of Gravity

To prevent a possible rollover subsequent to the side impact, vehicles with high centers of gravity (those classified by IIHS as sport utility vehicles, pickups, or passenger vans) will be tested with an antiroll device attached to the nonstruck side of the vehicle (Figure 5). The antiroll device is made primarily of 4130 Chromoly structural tubing and weighs 42.5 kg. It attaches to the vehicle where the roof rail intersects the B-pillar and at two points on the pinch welds under the door sill. The device is designed to allow the vehicle to rotate up to 5 degrees before further rotation is countered by a spring (14.8 kN/m) in the upper support member, which will allow an additional 5 degrees of rotation before bottoming out. Detailed drawings of the antiroll device are available free of charge from the Institute's website, www.highwaysafety.org, "Technical Information for Automotive Safety Engineers."

Figure 5
Antiroll Device for Tests of Sport Utility Vehicles, Pickups, and Passenger Vans



Test Vehicle Mass and Weight Distribution

The test weight of the vehicle, which includes the vehicle instrumentation, three cameras, and two SID-IIIs dummies, is 150–200 kg greater than the measured curb weight of the vehicle (as delivered from the dealer with full fluid levels). If the vehicle test weight needs to be increased to fall within the range, ballast weight is distributed in a manner that comes closest to replicating the original front/rear and left/right weight distributions of the vehicle. If the vehicle test weight needs to be decreased, nonessential, nonstructural items are removed from the rear of the vehicle.

Driver Seat and Driving Control Placement

The driver seat and adjustable steering controls are adjusted according to the *Guidelines for Using the UMTRI ATD Positioning Procedure for ATD and Seat Positioning (Version IV)* (IIHS, 2004). The outboard upper seatbelt anchorage point (if adjustable) is set in the full-down position, unless otherwise specified by the test vehicle's manufacturer. After the driver seat has been adjusted, the latching mechanism is examined to note whether all of its components are interlocked. If partial interlocking is observed and normal readjustment of the seat does not correct the problematic misalignment, the condition is noted and the test is conducted without repairing the mechanism. The right front passenger seat is set to match the position of the driver seat.

The driver's head restraint (if manually adjustable) is set in the full-down position, unless otherwise specified by the test vehicle's manufacturer. The head restraint height adjustment locking mechanism (if equipped) is examined to ensure the mechanism has engaged. All manually adjustable head restraint tilting mechanisms are adjusted to their full-rearward position.

The driver seat manually adjustable inboard armrest (if equipped) is moved to its lowered position. For vehicles equipped with multiple locking armrest positions, the position that results in the top surface of the armrest being closest to parallel with the ground is chosen. When seats have inboard and outboard armrests, both are placed in the lowered position.

Rear Passenger Seat Placement

If applicable, the rear passenger seat is placed in the full-rear fore/aft position or the position specified by the manufacturer. If a seat is vertically adjustable, it should be placed in its full-down position. The seatback angle should be set to 23 degrees, as measured by an H-point manikin torso angle or the angle specified by the manufacturer.

The rear passenger's head restraint (if manually adjustable) is set in the full-down position, unless otherwise specified by the test vehicle's manufacturer. The head restraint height adjustment locking mechanism (if equipped) is examined to ensure the mechanism has engaged. All manually adjustable head restraint tilting mechanisms are adjusted to their full-rearward position.

The rear seat manually adjustable inboard armrest (if equipped) is moved to its lowered position. For vehicles equipped with multiple locking armrest positions, the position that results in the top surface of the armrest being closest to parallel with the ground is chosen. When seats have inboard and outboard armrests, both are placed in the lowered position.

Side Windows and Door Locks

The nonstruck side doors are fully latched and locked, whereas the struck side doors are fully latched but not locked. The front and rear drivers side windows are fully raised.

Transmission and Ignition

The ignition is turned to its on position, and the transmission is shifted into its neutral position prior to the test. The front left tire is chocked to prevent the vehicle from moving prior to the test.

Crash Dummy Preparation and Setup

A 5th percentile female SID-IIs dummy is positioned in the driver seat according to the *Guidelines for Using the UMTRI ATD Positioning Procedure for ATD and Seat Positioning (Version III)* (IIHS, 2003). A second SID-IIs dummy is positioned in the left rear seat according to the *Dummy Seating Procedure for Rear Outboard Positions* (IIHS, 2002b).

Standard Build Level C SID-IIs (First Technology Safety Systems, 2002) dummies are used for the IIHS side impact program. Photographic targets are placed on both sides of the head to mark the location of its center of gravity.

The dummies used in these tests are calibrated according to the parameters established by the OSRP SID-IIs Upgrade Taskgroup (First Technology Safety Systems, 2002) after being subjected to no more than five crash tests. Additionally, the shoulder, thorax, and abdomen regions are individually recalibrated if deflections recorded during a test exceed 50 mm or if postcrash inspection reveals damage. All visible damage is repaired before the dummy is used again.

The dummies and vehicle are kept in a climate-controlled area in the crash hall where the temperature is maintained at 20.6–22.2 degrees Celsius and the relative humidity at 10–70 percent for at least 16 hours prior to the test. The driver and rear passenger seat belts are fastened around the dummies. For vehicles with continuous-loop lap/shoulder seat belts, the slack from the lap portion of the driver seat belt is removed and the webbing is pulled fully out of the retractor and allowed to retract under tension a total of four times. The lap belt slack is then removed again with a small pulling force. For vehicles with separate lap and shoulder seat belt retractors, the webbing from each is pulled fully out of the retractor and allowed to retract under tension a total of four times. Prior to the crash, the heads of both dummies are colored with grease paint to facilitate postcrash identification of impacts with the vehicle interior and/or the striking barrier face.

Photography

Still Photography

The precrash and postcrash conditions of each test vehicle are photographed. Two precrash views and two postcrash views show the side and left front quarter of the test vehicle. Additional photographs document the precrash position of the driver and rear passenger dummies.

Three standard views each of the vehicle and MDB together in their postcrash positions, of the struck side of the vehicle, and of the MDB face are recorded. Additional photographs document the postcrash positions of the driver and rear passenger dummies, as well as any paint transfer areas due to dummy contact with the vehicle or MDB. Once the dummies are removed from the vehicle, both seating compartment areas are photographed as a means of illustrating vehicle intrusion. Additional photographs are taken with the struck side with door skins removed, then again with the doors removed.

High-Speed Motion Picture Photography

Motion picture photography is made of the test with twelve high-speed 16 mm film cameras and three real-time video cameras. The lens focal length of each onboard high-speed camera are described in Table 1. Frame rates for the 16 mm cameras are accurate to ± 1 percent of the set frame rate. The positions of the offboard and on board cameras are illustrated in Figures 6A and 6B, respectively.

Table 1
MDB and Onboard High-Speed (500 frames per second) Camera Focal Point and Settings

	H	I	J	K
Camera Position	Centered On MDB	Rear Passenger Window Sill	Front Passenger Window Sill	Front Passenger Window Sill
Focal point	Impact from perspective of MDB	Lateral view of rear passenger	Lateral view of driver	Driver and rear passenger head
Focal length (mm)	10	7.5	7.5	10

Figure 6A
Offboard and MDB High-Speed (500 frames per second) Camera Positions in Crash Hall

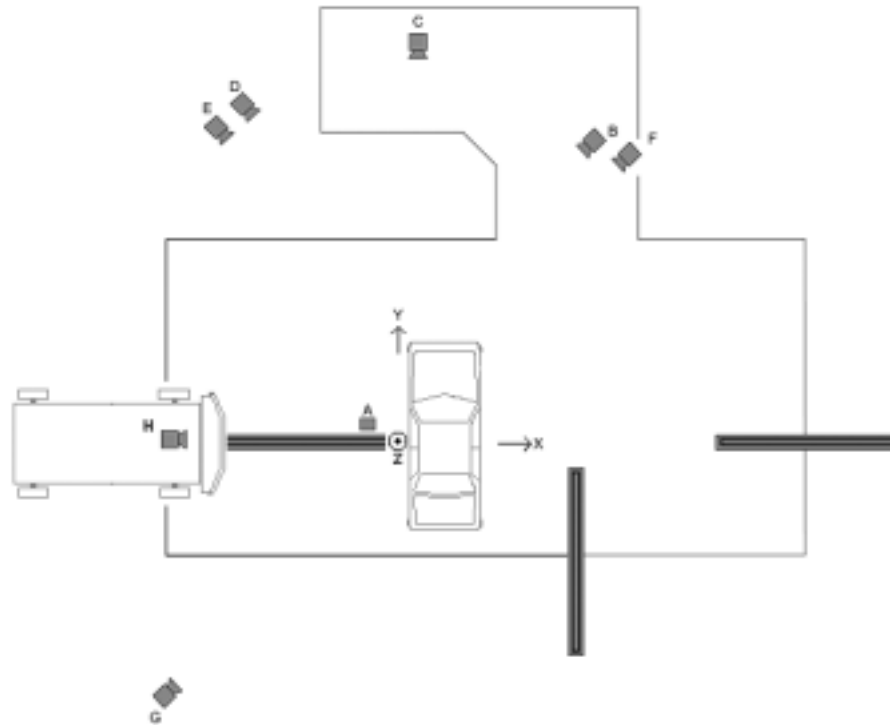
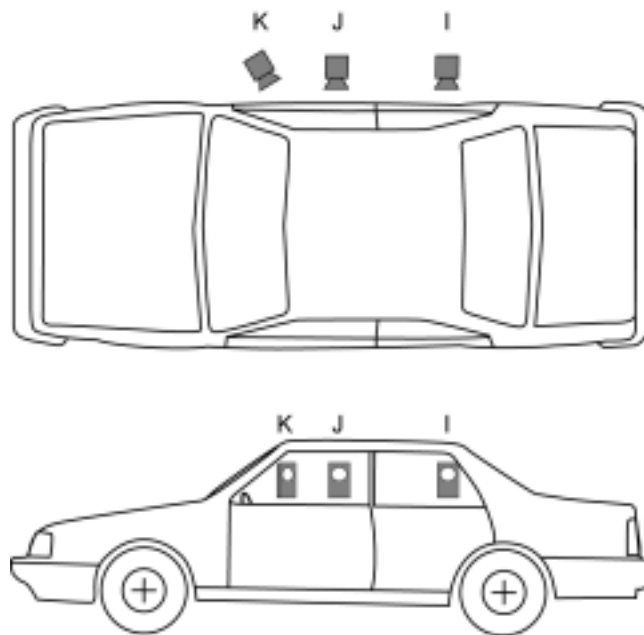

Figure 6B
Onboard High-Speed (500 frames per second) Camera Positions



Measurements/Observations

Test Weight

The test weight of the vehicle is measured at each of the four wheels. The vehicle is weighed with all test equipment installed including the driver and passenger dummies. In tests of sport utility vehicles, pickups, and passenger vans, the test weight is measured without the antiroll device attached. The front and rear axle weights are used to determine the longitudinal position of the center of gravity for the test vehicle.

Impact Speed

The barrier impact speed is determined by averaging two speed trap measurements. Both speed traps measure the average velocity of the barrier between 1.0–1.5 m before impact with the vehicle. The propulsion system also has an optical speed measuring device that serves as a backup to the two speed traps. This device measures the speed of the hardware attaching the barrier to the propulsion system immediately prior to barrier's release from the propulsion system before impact. The speed is clocked over a 1 m length of vehicle travel ending 0.5 m before the barrier's release from the propulsion system.

Impact Point

A threaded 0.125 inch (3 mm) rod with a sharpened tip is attached to a tapped hole in the leading edge of the MDB bumper aluminum cladding. The horizontal location of this impact striker is selected such that it contacts the rear door at the point of impact. The impact striker extends 20–30 mm from the front edge of the barrier face, thus it makes first contact between the barrier and the vehicle. A 3 inch (76 mm) diameter photo target is placed on the vehicle (Figure 4) so that the tip of the impact striker is located in the center of the target during precrash vehicle positioning. At the point of impact, the striker punctures the target, thus providing an indication of the initial MDB alignment with respect to the vehicle.

Vehicle Accelerations

The lateral acceleration of the vehicle's occupant compartment is measured (Endevco 7264A-2000 accelerometers) at two locations on the floor, just rearward of the A- and B-pillars, and recorded by IDDAS. Positive vehicle accelerations are to the right along the lateral axis. The data are presented filtered according to the channel frequency class (CFC) 60 as defined in SAE J211 – Instrumentation for Impact Tests (Society of Automotive Engineers (SAE), 2000).

Fuel System Integrity

Observations about fuel system integrity are recorded for each test. Any Stoddard fluid leaked from the fuel system within 1 minute after the impact is collected as the first sample. This typically is done by soaking up the fluid with an absorbent pad of known mass. The second sample of leaked Stoddard fluid is collected during the 5 minutes immediately following the collection of the first sample. This sample typically is collected in pans placed under the sources of identified leaks. The third sample is collected during the 25 minutes immediately following the

collection of the second. The pans used to collect the second sample are replaced with clean empty pans. The volume of each sample is determined by dividing the weight of the sample by the density of Stoddard fluid (790 g/l). The elapsed time is determined using a stopwatch. The entire process is recorded with a video camera equipped with an internal timer, which displays the time in each frame.

Vehicle Crush Profile and Compartment Intrusion

The spatial coordinates of the test vehicle's centerline and the profile of the driver's side structure are measured before and after the crash. Three horizontal contour lines are marked on the driver's side of the vehicle at the level of the window sill, mid-door, and rocker panel (Figure 4) and then recorded using a coordinate measuring machine (FARO Technologies Inc.). These contour lines are measured after the crash using the same reference coordinate system. Precrash and postcrash vertical profiles of the front and rear passenger doors also are recorded. These profiles are taken on the door exterior and interior trim at the horizontal locations corresponding to the dummies' H-point positions (as measured prior to the test). Figure 7 shows example measurements of the door cross section and its position with respect to the dummy. The vertical location of the dummy H-point also is recorded on the vertical line both on the door exterior and the interior trim. Precrash and postcrash measures are recorded on the struck-side B-pillar exterior and the non-struck-side B-pillar exterior and interior (with interior trim removed); postcrash measures are also recorded on the struck-side B-pillar interior (with interior trim removed). Precrash measures on the struck-side B-pillar interior are not recorded due to the possibility that removal and reattachment of the interior trim could affect the deployment of roof-rail-mounted head curtain airbags. A mirror image of the non-struck-side B-pillar interior vertical profile will be used to determine the relative movement of the B-pillar interior. Figure 8 shows example precrash and postcrash B-pillar vertical profile measures.

Coordinate system definition: A right-handed, three-axis orthogonal coordinate system is used for these measures: longitudinal (front to rear is positive), lateral (left to right is positive), and vertical (bottom to top is positive).

The precrash coordinate system is defined with the vehicle unloaded (no occupants) on a level floor. The plane of the ground is used to define the X-Y plane, and the two end points on the centerline of the roof are used to define the X-axis (Figure 4). Coordinates of three marked reference points on the non-struck-side vehicle structure are recorded precrash to establish the postcrash coordinate system.

Figure 7
Example Door Vertical Profile Measures at Driver H-Point

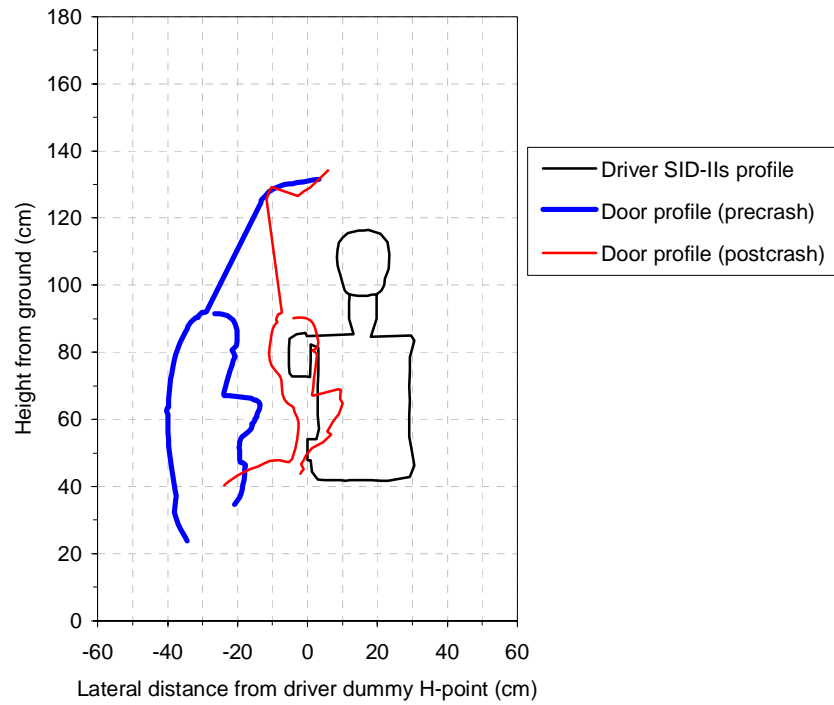
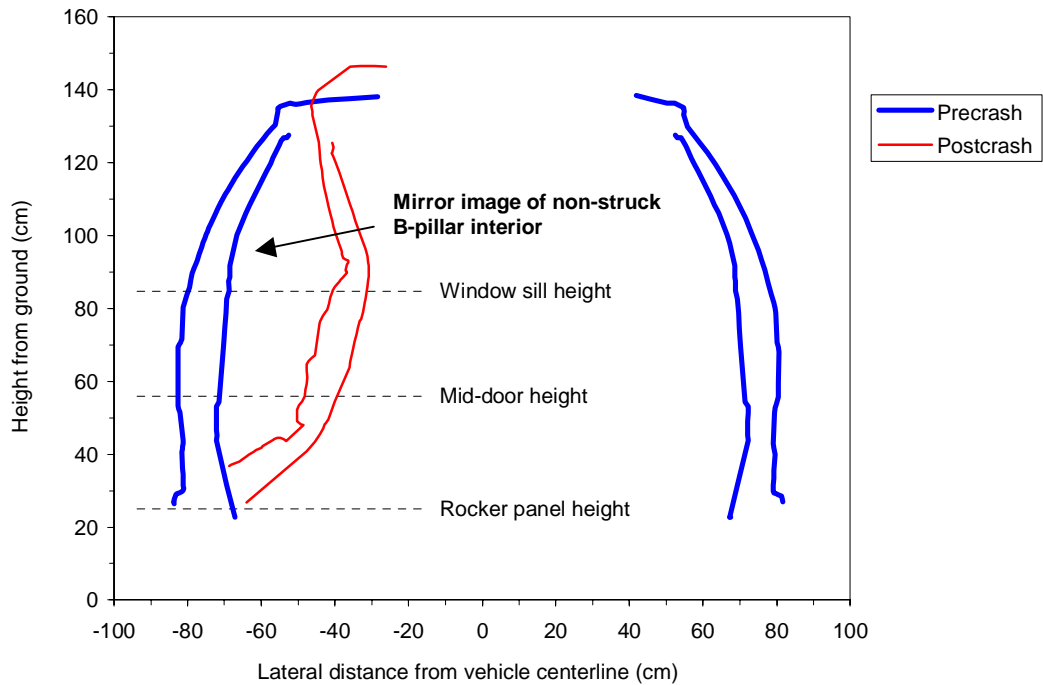

Figure 8
Example B-Pillar Vertical Profiles



MDB Crush Profile

Vertical lines are marked with one inch tape and recorded with a coordinate measurement machine at the left edge, right edge, and center of the face of the deformable element. Horizontal measurements are taken along the top edge, mid-bumper, and 19 cm above the top surface of the bumper (Figure 9).

Figure 9
Front View of Markings on MDB

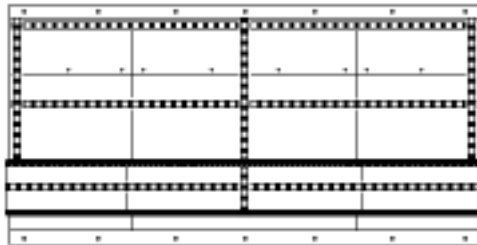

Dummy Kinematics and Contact Locations

Both dummies are inspected in their undisturbed postcrash positions. Any damage to or unusual final resting position observed for either dummy is documented. The locations of grease paint transferred from the heads of the dummies to the vehicle interior and/or barrier face are noted and photographed. Any entrapment of the lower extremities also is documented when the dummies are extricated from the vehicle.

Review of the high-speed film using a film analyzer and analysis software helps determine dummy kinematics and estimate the time after the start of the crash that various events occur. For each event, the camera that provides the clearest view of the event is used. The start of the crash is considered to be the first frame in the film from each camera in which the LEDs mounted on the roof and inside the vehicle are illuminated. The time recorded for each event is based on the number of frames elapsed from the start of the crash and the nominal operating speed of the camera. For the cameras operating at 500 frames per second, the estimate of the crash's start time can be up to 2 ms late, and the event's time, as determined from the film, can be early or late by 2 ms. The time of the driver and passenger side airbag deployment, full inflation, and first dummy contacts are recorded as well as any other notable events.

Dummy Responses

Each SID-II's dummy is equipped with instrumentation for measuring the following:

Head

Tri-axial accelerations (three Endevco 7264B-2000* accelerometers)

Neck

A-P shear force
L-M shear force
Axial force

A-P moments
L-M moments
Twist moments (FTSS IF-205 or R.A. Denton 1716A load cell)

Shoulder

Triaxial forces (FTSS IF-344 or Denton 3167 load cell)
Lateral shoulder compression (FTSS 180-3860 linear potentiometer)

Spine

T1, base of the neck, lateral acceleration (Endevco 7264B-2000* accelerometer)
T4, first thoracic rib level, lateral acceleration (Endevco 7264B-2000* accelerometer)
T12, first abdominal rib level, lateral acceleration (Endevco 7264B-2000* accelerometer)

Chest and Abdominal Ribs (three thorax and two abdominal ribs)

Struck side lateral rib accelerations (Endevco 7264B-2000* accelerometers)
Lateral rib compressions (FTSS 180-3861 linear potentiometers)

Pelvis

Tri-axial accelerations (three Endevco 7264B-2000* accelerometers)
Lateral acetabulum force (FTSS IF-520 or R.A. Denton 3249 load cell)
Lateral ilium crest force (FTSS IF-507 or R.A. Denton 3228 load cell)

Lower Extremities

Left lower femur forces (three axis) and moments (three axis) (FTSS IF-625 or R.A. Denton 1914A load cell)

*Endevco 7264A-2000 accelerometers also may be used

All instruments are regularly calibrated to a known standard. Accelerometers and load cells are calibrated every 12 months. All measurements recorded from these instruments comply with the recommendations of SAE Information Report J1733 – Sign Convention for Vehicle Crash Testing DEC94 (SAE, 2000).

The two Denton IDDAS, which are installed on the passenger side window sill platforms, are used for all dummy and vehicle data acquisition. During the crash, all measurements are recorded in the system's random access memory with 12-bit resolution at a sample rate of 10 kHz. Signals in all channels convert simultaneously, so the time reference for different channels is not skewed. To ensure digital fidelity, all signals are filtered by an analog low-pass prefilter with a 2.5 kHz cutoff frequency.

After the data have been downloaded from the IDDAS, any initial offset from zero is removed from each channel by computing the mean value for 100 data points preceding the crash event (from 50 to 40 ms before impact) for each channel and subtracting each mean from the respective data channel. With the exception of rib deflection and pelvic acceleration data, which are filtered to SAE CFC 180, all other data are digitally filtered using the frequency response classes recommended in SAE Recommended Practice J211/1 – Instrumentation for Impact Test – Part 1.

Electronic Instrumentation MAR95 (SAE, 2000). All filtering and subsequent calculations are executed using DSP Development Corporation's (2002) DADiSP Version 6.0 NI NK B03.

In addition to summary metrics for each of the recorded data channels, the following calculations are made: vector resultant of the head acceleration; 3 ms clip of the vector resultant head acceleration; head injury criterion (HIC), 15 ms; thoracic and abdominal rib deflection rate (calculated by differentiating the rib deflection data); thoracic and abdominal viscous criterion; 3 ms clip of the anterior-posterior and lateral-medial femur forces; and 3 ms clip of the anterior-posterior and lateral-medial femur bending moments.

The head injury criterion (HIC) is calculated as follows:

$$HIC = \left[\frac{1}{(t_2 - t_1)} \int_{t_1}^{t_2} a(t) dt \right]^{2.5} (t_2 - t_1) \quad (\text{Eq. 1})$$

where,

$a(t)$ = resultant head acceleration

t_1, t_2 = start and stop times of the integration, which are selected to give the largest HIC value.

For the HIC analysis, t_1 and t_2 are constrained such that $(t_2 - t_1) \leq 15$ ms.

The velocity (deflection rate) for each rib is calculated by differentiating the rib deflection data:

$$V(t)_i = \dot{D}(t)_i \quad (\text{Eq. 2})$$

where,

$D(t)_i$ = the deflection of rib i at time t , measured with linear potentiometers and filtered to SAE CFC 180 (mm).

The viscous criterion (VC) for each rib is calculated as follows:

$$VC(t)_i = 1.0 * V(t)_i * \frac{D(t)_i}{138mm} \quad (\text{Eq. 3})$$

where,

$V(t)_i$ = the velocity of rib i at time t , from Eq. 2 (m/s)

$D(t)_i$ = the deflection of rib i at time t , measured with linear potentiometers and filtered to SAE CFC 180 (mm).

A total struck side lateral pelvic force ($F_P(t)$) is computed by adding the instantaneous lateral acetabulum ($F_A(t)$) force with the instantaneous lateral iliac force ($F_I(t)$):

$$F_P(t) = F_A(t) + F_I(t) \quad (\text{Eq. 4})$$

References

Arbelaez, R.A.; Dakin, G.J.; Nolan, J.M.; Dalmotas, D.J.; and Tylko, S. 2002. IIHS side impact barrier: development and crash test experience. *IMEchE Conference Transactions: International Conference on Vehicle Safety 2002*, 73-88. London, United Kingdom: Professional Engineering Publishing Ltd.

Dakin, G.J.; Arbelaez, R.A.; Nolan, J.M.; Zuby, D.S.; and Lund, A.K. 2003. Insurance Institute for Highway Safety side impact crashworthiness evaluation program: Impact configuration and rationale. *Proceedings of the 18th International Technical Conference on the Enhanced Safety of Vehicles* (CD-ROM). Washington, DC: National Highway Traffic Safety Administration.

DSP Development Corporation. 2002. DADiSP Ver. 6.0 NI NK B03. Cambridge, MA.

First Technology Safety Systems. 2002. Product Service Bulletin, SID-IIs. TR-SID-IIs-2002-08-21. Plymouth, MI.

Insurance Institute for Highway Safety. 2002a. Low-speed crash test protocol (version V). Arlington, VA.

Insurance Institute for Highway Safety. 2002b. Dummy seating procedure for rear outboard positions. Arlington, VA.

Insurance Institute for Highway Safety. 2004. Guidelines for using the UMTRI ATD positioning procedure for ATD and seat positioning (version IV). Arlington, VA.

Society of Automotive Engineers. 2000. *2000 SAE Handbook, Vol. 3 – On-Highway Vehicles and Off-Highway Machinery*. Warrendale, PA.

APPENDIX
Driver Dummy Clearance Measurement Definitions

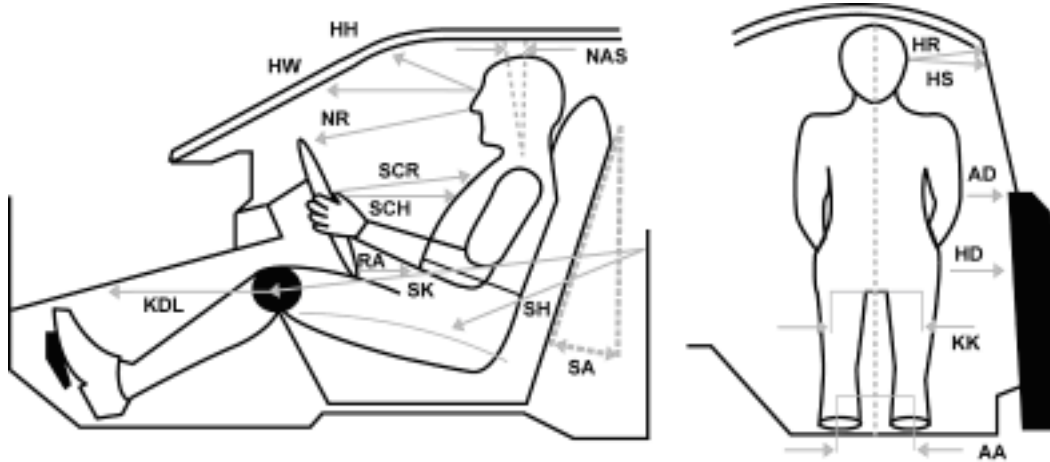

Driver Dummy Measures

Location	Code	Definition of Measurement
Ankle to ankle	AA	Taken between the center points of both ankles, after the feet are placed per Institute protocol.
Arm to door	AD	Horizontal measurement taken from the center point of the elbow to the first contact point of the door panel.
Head to A-pillar	HA	Horizontal measurement taken from the center of the head's outboard CG target to the A-pillar. <i>(not shown in figure)</i>
Hub to chest, minimum	HCM	Minimum horizontal distance measured from the hub to the dummy's chest. <i>(not shown in figure)</i>
H-point to door	HD	Horizontal measurement taken from the H-point hole to the first contact point of the door panel.
Head to header	HH	Taken from center point between eyes to header directly in front of dummy.
Head to roof	HR	Taken from the center of the outboard target to the roof edge (not the upper edge of the car door), perpendicular to the long axis of the car. If a tape measure is held from the target and extends below the roof, the point to measure is at the low edge of the roof line, which will make contact with the tape measure.
Head to side window	HS	Taken from the center of the outboard target to the side window, measured horizontally and perpendicular to the long axis of the car. In cases where the window is not fully up, a flat bar should be placed across the window opening to simulate the position of the window.
Head to windshield	HW	Taken from the center point between dummy's eyes to the point on the windshield directly level with the dummy's forehead.
Knee to dash, left	KDL	Taken from the knee pivot point to the point on the dash that is directly level with the center of the knee.

continued

Location	Code	Definition of Measurement
Knee to knee	KK	With the legs in a vertical plane after the feet are placed per Institute protocol, the measurement is taken from outside flange to outside flange of the knees. The minimum distance is 270 mm (10.6 inches).
Neck angle, seated	NAS	Taken from the neck when the dummy is seated across two of the "vertebral disks" of the neck.
Nose to rim	NR	Taken from the tip of the nose to the steering wheel rim at the 12 o'clock position.
Pelvic angle	PA	Taken from the instrumented pelvis sensor (if available) or by placing an inclinometer on the H-point bar, which is used to align the H-point with previous measurements.
Rim to abdomen	RA	Taken from the point where the bottom of the chest jacket and the pelvic structure meet to the steering wheel rim at the 6 o'clock position.
Seat back angle	SA	Taken from the lower left corner of the driver's seat back unless otherwise directed by the manufacturer at which time it will be properly noted along with the measurement.
Steering wheel to chest, horizontal	SCH	Horizontal measurement taken from the center of the steering wheel to the dummy's chest.
Steering wheel to chest, reference	SCR	Taken from the center of the steering wheel to the top rib guide (SID-IIs dummies).
Striker to H-point, horizontal	SHH	Horizontal measurement taken from the H-point to the driver door striker. Value is negative if the H-point is forward of the striker.
Striker to H-point, lateral	SHL	Lateral measurement taken from the H-point to the driver door striker.
Striker to H-point, vertical	SHV	Vertical measurement taken from the H-point to the driver door striker. Value is negative if the H-point is below the striker.
Striker to knee	SK	Taken from the center point of the knee to the front door striker.
Striker to knee angle	SKA	Calculated using the coordinates of the knee pivot point and the location of the driver door striker.

APPENDIX
Rear Passenger Dummy Clearance Measurement Definitions

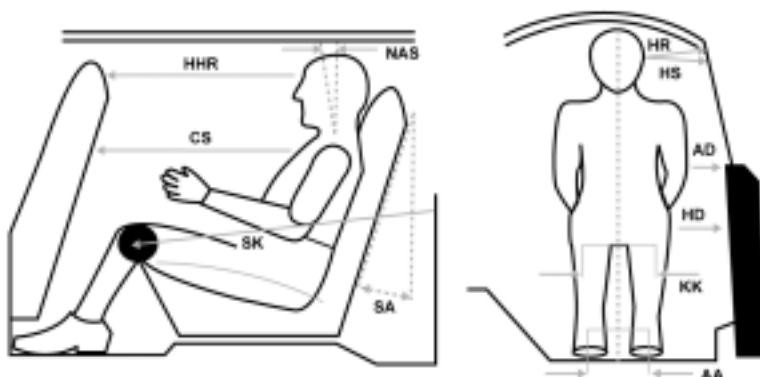

Rear Passenger Dummy Measures

Location	Code	Definition of Measurement
Ankle to ankle	AA	Taken between the center points of both ankles, after the feet are placed per Institute protocol.
Arm to door	AD	Horizontal measurement taken from the center point of the elbow to the first contact point of the door panel.
Chest to seat	CS	Horizontal measurement taken from the top rib guide in the chest to a point on the back of the driver seat.
Head to B-pillar	HB	Horizontal measurement taken from the center of the head's outboard CG target to the B-pillar. <i>(not shown in figure)</i>
H-point to door	HD	Horizontal measurement taken from the H-point hole to the first contact point of the door panel.
Head to head restraint	HHR	Horizontal measurement taken from center point between eyes to the back side of the driver head restraint directly in front of the dummy.
Head to roof	HR	Taken from the center of the outboard target to the roof edge (not the upper edge of the car door), perpendicular to the long axis of the car. If a tape measure is held from the target and extends below the roof, the point to measure is at the low edge of the roof line, which will make contact with the tape measure.
Head to side window	HS	Taken from the center of the outboard target to the side window, measured horizontally and perpendicular to the long axis of the car. In cases where the window is not fully up, a flat bar should be placed across the window opening to simulate the position of the window.
Knee to knee	KK	With the legs in a vertical plane after the feet are placed per Institute protocol, the measurement is taken from outside flange to outside flange of the knees. The minimum distance is 270 mm (10.6 inches).

continued

Location	Code	Definition of Measurement
Neck angle, seated	NAS	Taken from the neck when the dummy is seated across two of the “vertebral disks” of the neck.
Pelvic angle	PA	Taken from the instrumented pelvis sensor (if available) or by placing an inclinometer on the H-point bar, which is used to align the H-point with previous measurements.
Seat back angle	SA	Taken from the lower left corner of the rear passenger’s seat back unless otherwise directed by the manufacturer at which time it will be properly noted along with the measurement.
Striker to H-point, horizontal	SHH	Horizontal measurement taken from the H-point to the driver door striker. Value is negative if the H-point is forward of the striker.
Striker to H-point, lateral	SHL	Lateral measurement taken from the H-point to the driver door striker.
Striker to H-point, vertical	SHV	Vertical measurement taken from the H-point to the driver door striker. Value is negative if the H-point is below the striker.
Striker to knee	SK	Taken from the center point of the knee to the rear door striker.
Striker to knee angle	SKA	Calculated using the coordinates of the knee pivot point and the location of the rear door striker.